

REVISIONS			
REV.	DESCRIPTION	DATE	APPROVED

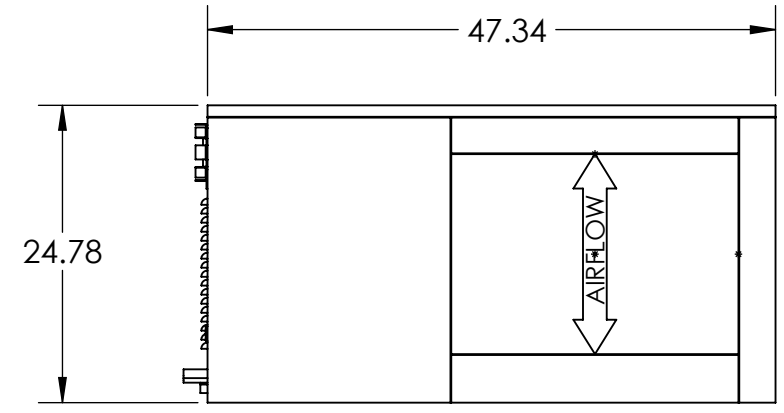
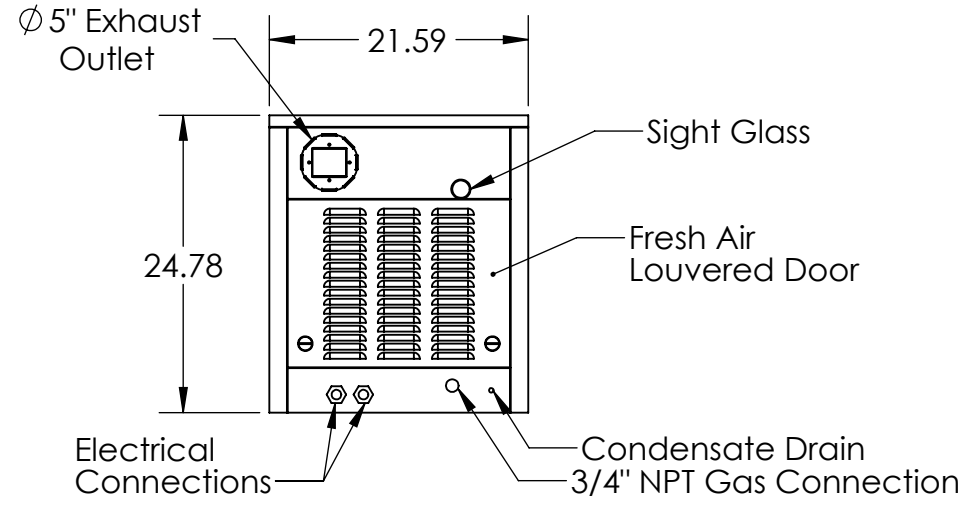
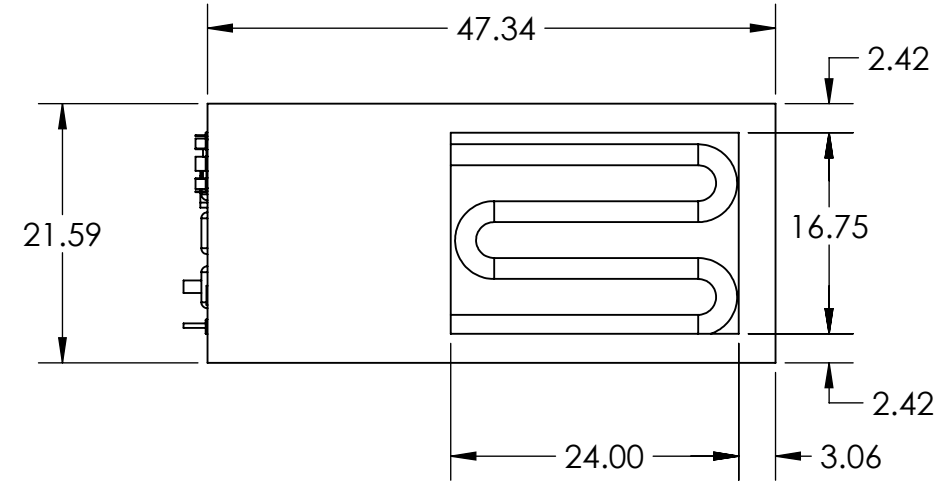
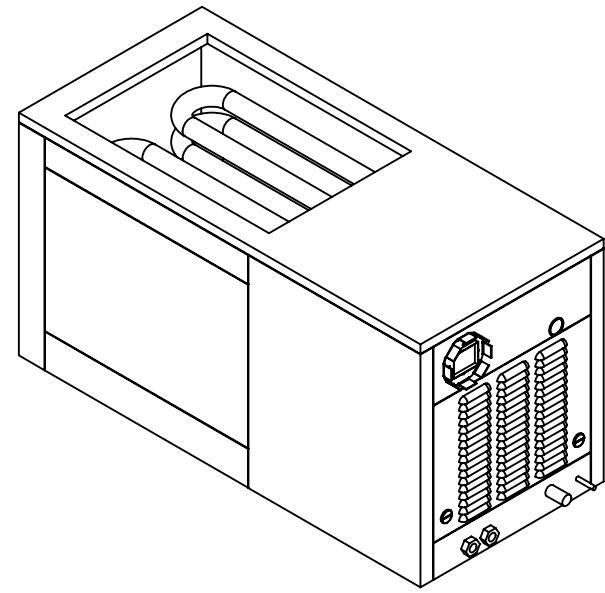

PROPRIETARY AND CONFIDENTIAL
 THE INFORMATION CONTAINED IN THIS DRAWING IS THE SOLE PROPERTY OF HEATCO INC. ANY REPRODUCTION IN PART OR AS A WHOLE WITHOUT THE WRITTEN PERMISSION OF HEATCO IS PROHIBITED.

UNLESS OTHERWISE SPECIFIED:	
DIMENSIONS ARE IN INCHES	
TOLERANCES:	
FRACTIONAL ±	
ANGULAR: MACH ± BEND ±	
TWO PLACE DECIMAL ±	
THREE PLACE DECIMAL ±	
INTERPRET GEOMETRIC TOLERANCING PER:	
MATERIAL	
FINISH	
DO NOT SCALE DRAWING	

NAME	DATE
JPence	12/18/2017
DRAWN	
CHECKED	
ENG APPR.	
MFG APPR.	
Q.A.	
COMMENTS:	

HEATCO 50 Heatco Ct.
 Cartersville Ga 30120
 1-800-554-1007

TITLE:

SIZE	DWG. NO.	REV
B	HDG150-I-KF	

SCALE: 1:16 WEIGHT: SHEET 1 OF 1

