

8 7 6 5 4 3 2 1

| REVISIONS |                         |          |          |
|-----------|-------------------------|----------|----------|
| REV.      | DESCRIPTION             | DATE     | APPROVED |
| A         | Revised exhaust extents | 2/8/2016 | JDP      |

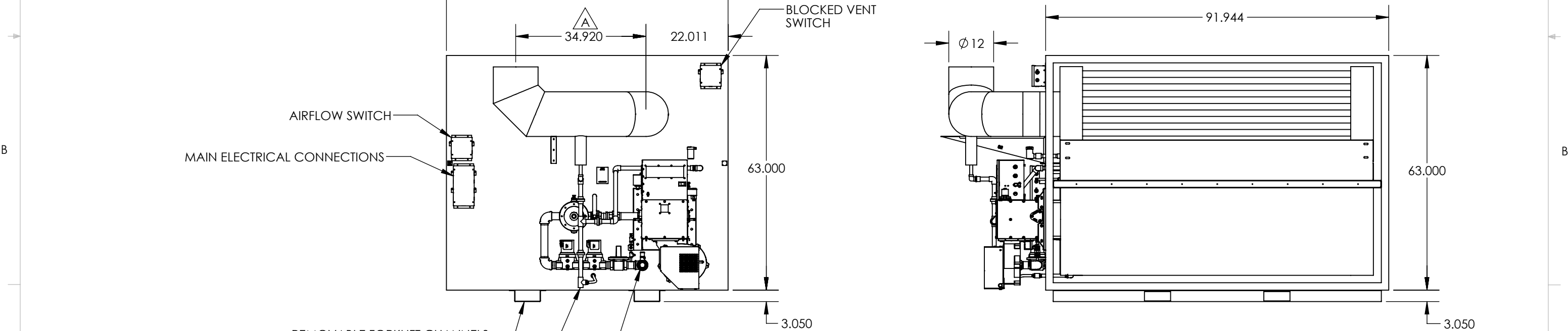
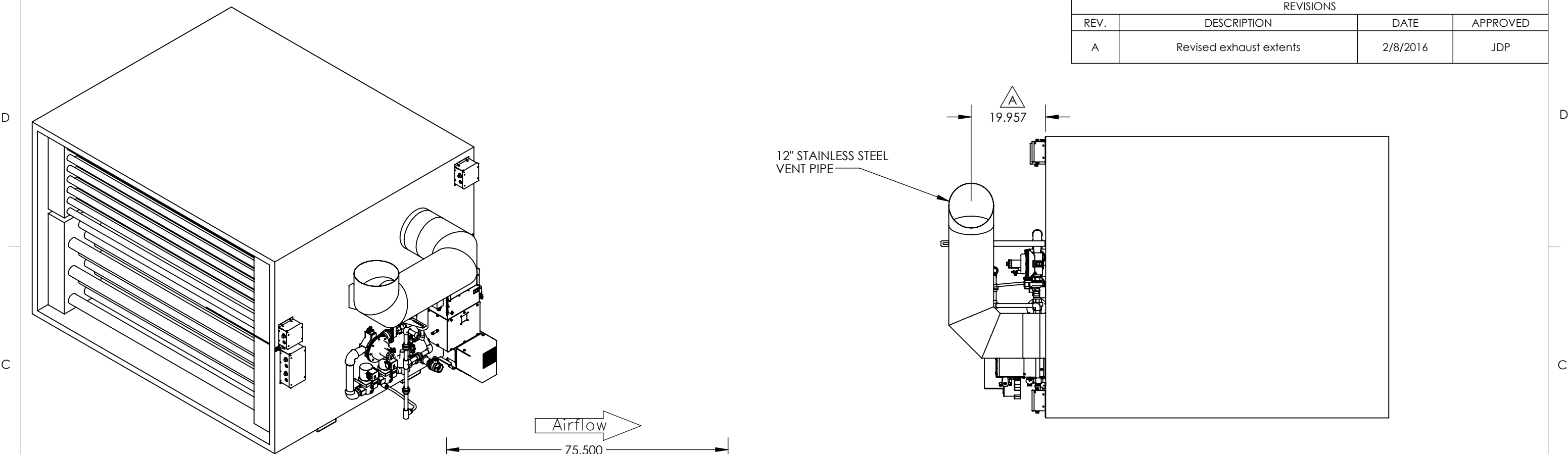

AIRFLOW SWITCH  
 MAIN ELECTRICAL CONNECTIONS  
 REMOVABLE FORKLIFT CHANNELS  
 3/4" PVC DRAIN CONNECTION  
 1-1/2" FPT GAS CONNECTION

**PROPRIETARY AND CONFIDENTIAL**  
 THE INFORMATION CONTAINED IN THIS DRAWING IS THE SOLE PROPERTY OF HEATCO INC. ANY REPRODUCTION IN PART OR AS A WHOLE WITHOUT THE WRITTEN PERMISSION OF HEATCO IS PROHIBITED.

|             |                                      |           |                |
|-------------|--------------------------------------|-----------|----------------|
|             | UNLESS OTHERWISE SPECIFIED:          | NAME      | DATE           |
|             | DIMENSIONS ARE IN INCHES             | DRAWN     | JPence 12/7/15 |
|             | TOLERANCES:                          | CHECKED   |                |
|             | FRACTIONAL ±                         | ENG APPR. |                |
|             | ANGULAR: MACH ± BEND ±               | MFG APPR. |                |
|             | TWO PLACE DECIMAL ±                  | Q.A.      |                |
|             | THREE PLACE DECIMAL ±                | COMMENTS: |                |
|             | INTERPRET GEOMETRIC TOLERANCING PER: |           |                |
|             | MATERIAL                             |           |                |
|             | FINISH                               |           |                |
| NEXT ASSY   | USED ON                              |           |                |
| APPLICATION | DO NOT SCALE DRAWING                 |           |                |

**HEATCO** 50 Heatco Ct.  
 Cartersville Ga 30120  
 1-800-554-1007

|             |                |              |
|-------------|----------------|--------------|
| TITLE:      |                |              |
| SIZE        | DWG. NO.       | REV          |
| <b>B</b>    | EF-1500-V4-A-T | <b>A</b>     |
| SCALE: 1:26 | WEIGHT:        | SHEET 1 OF 1 |

8 7 6 5 4 3 2 1